

User Manual

Barrier Gate - ProBG Series

Version: 1.0

Date: Jan. 2019

Contents

1 Product Installation	1
1.1 Installation Precautions	1
1.2 Cable Embedding	1
1.3 Installation Procedure	2
1.4 Boom Installation	2
2 Springs Testing and Adjustment.....	3
2.1 Adjust the Position of Barrier Arm.....	3
2.2 Adjustment Spring Setting	5
2.3 Testing Spring Setting	5
3 Power Connection	6
4 Control Board Introduce.....	7
4.1 Function Instruction:	7
4.2 Input Interface Introduction	8
4.3 Output Interface Introduction	8
4.4 Optional Functions.....	9
5 Appendix.....	13
5.1 Remote Control Learning Code Instruction.....	13
5.2 Up/Down Speed Parameter Adjustments Instruction	13

1 Product Installation

1.1 Installation Precautions

- 1) Install the parking barrier on a level ground. If the ground is not solid and level, a cement base is needed before installation.
- 2) Do not change the wire connection inside when power on.
- 3) The GND should be connected to the cabinet for secure protection.

1.2 Cable Embedding

- 1) Prepare $\phi 25$ protective sleeve and cable in advance.
- 2) Route cables to be connected through protective sleeves.
- 3) Use a tool to open a cable tray on the ground.

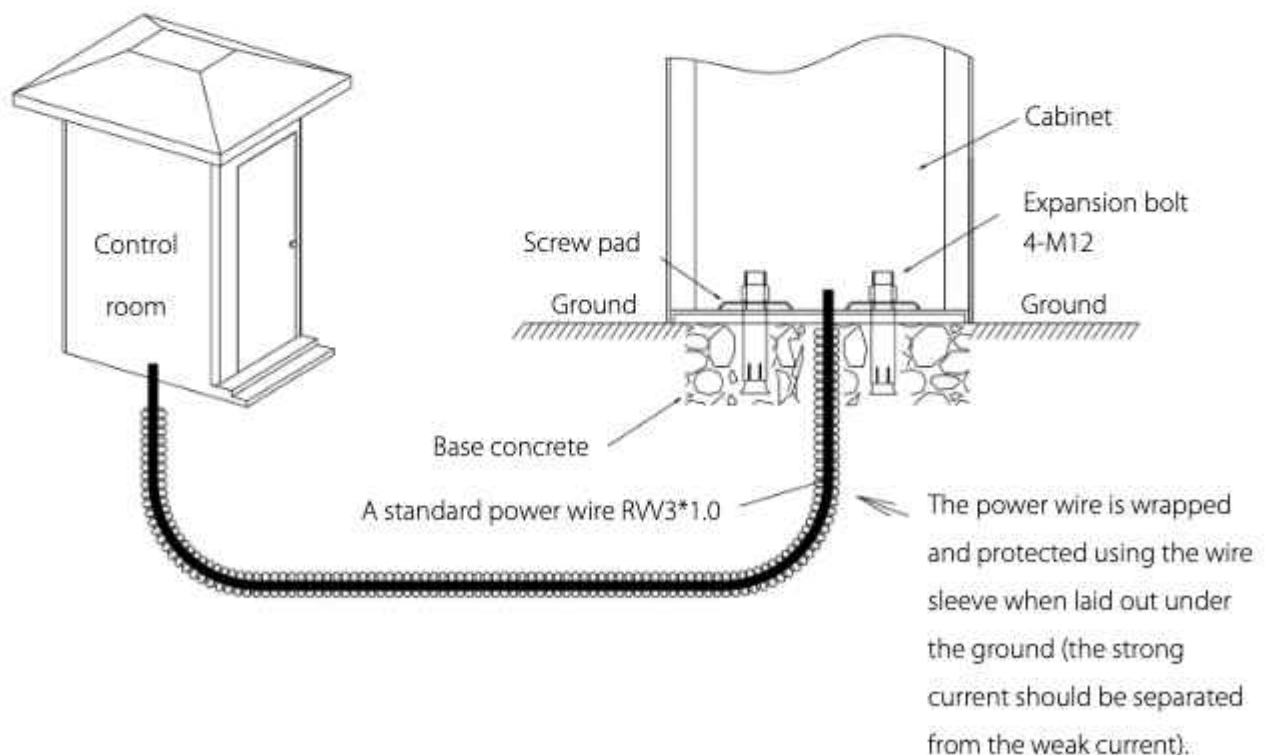

Figure 1-1

1.3 Installation Procedure

- 1) Use screw pad to mark the installation position of the cabinet.
- 2) Drive four expansion bolts into the bolt holes, as shown in Figure 1-2.
- 3) Install screw pads and use a wrench to tighten nuts, as shown in Figure 1-3.

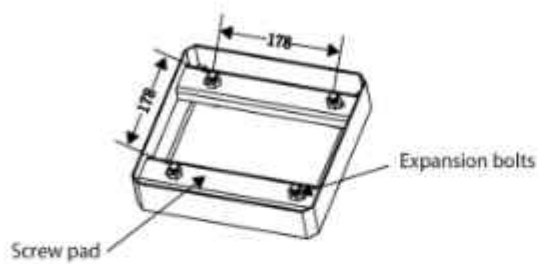

Figure 1-2

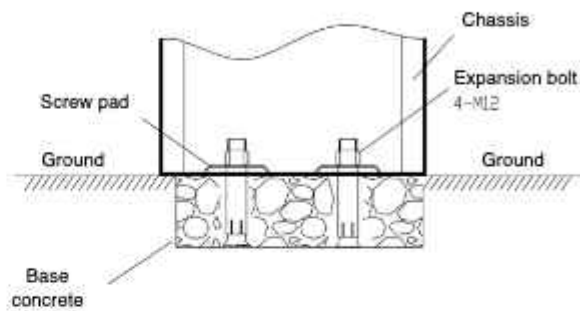

Figure 1-3

1.4 Boom Installation

- A: put the boom into boom tray head according to the hole location.
- B: use the spanner to clamp the round boom by screws, gasket and screws nut.

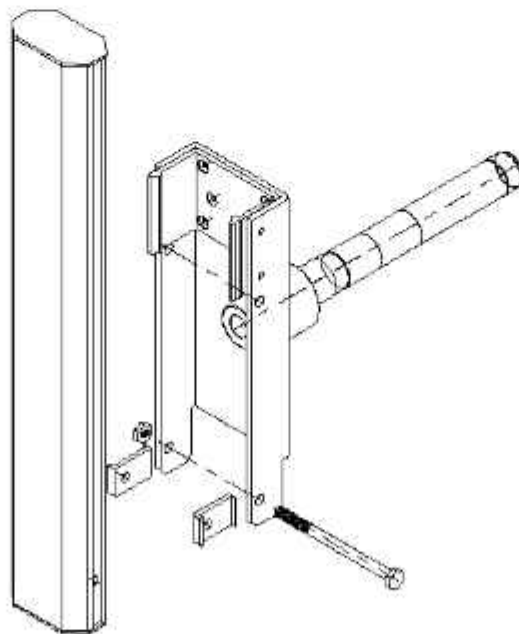

Figure 1-4

2 Springs Testing and Adjustment

Note: All of the barrier gates already set up in the factory based on the original boom. The spring inside of the mechanism is in a highly tense status. And all the adjustment of the barrier must be carried on after the spring is in loose status and the boom is put aside. But when you use it, please check the boom's setting after installed it and on the first operation. After the weight of boom is balanced by the tension applied by the spring, the barrier gate can be operated correctly. Therefore, any changes to the boom must be re-adjusted according to the following steps.

2.1 Adjust the Position of Barrier Arm

To adjust the position of the boom (for example, after exerting excessive force), please take the steps as below:

1. Open the barrier gate door and remove the cover.
2. Loosen the two fasten screws of the DZ-1 on the boom shaft with the M12's Allen wrench, so that the boom can be repositioned by hand.
3. Adjust the position of the boom (horizontal position, as shown in figure 2-1).
4. Use the torque wrench to tighten the two fastening screws (72 Nm).

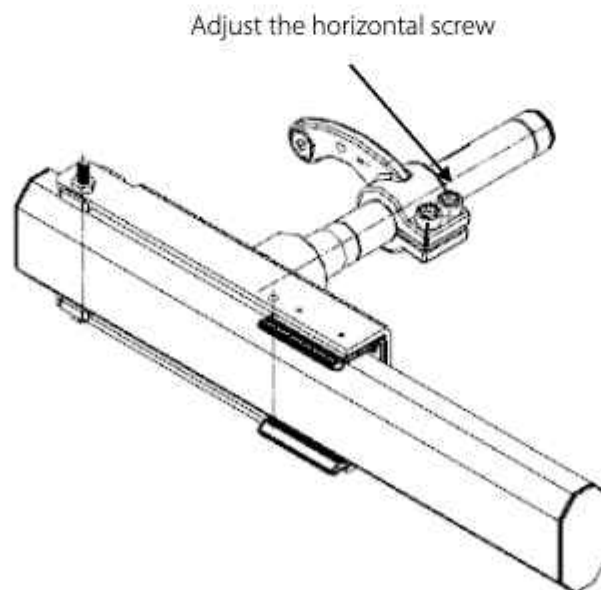

Figure 2-1

Manually Unlocked Open/Close Arm When Power Off

The barrier gate may into the vertical or horizontal mechanical dead point position when power off, if manually up/down the arm at this time, please follow the steps as below:

1. Make the key rotate clockwise 90 degrees and open the door (shown in figure 2-2).
2. Unscrew the two butterfly nuts upward, open the cover.
3. Lifting the boom: use the screwdriver to push the crank connected rod away from the dead point position, rise up the barrier gate manually (Push to Unlock).
4. Dropping the boom: use the hand to pull the crank connected rod down to leave the dead point position, drop the barrier gate manually (Pull to Unlock).

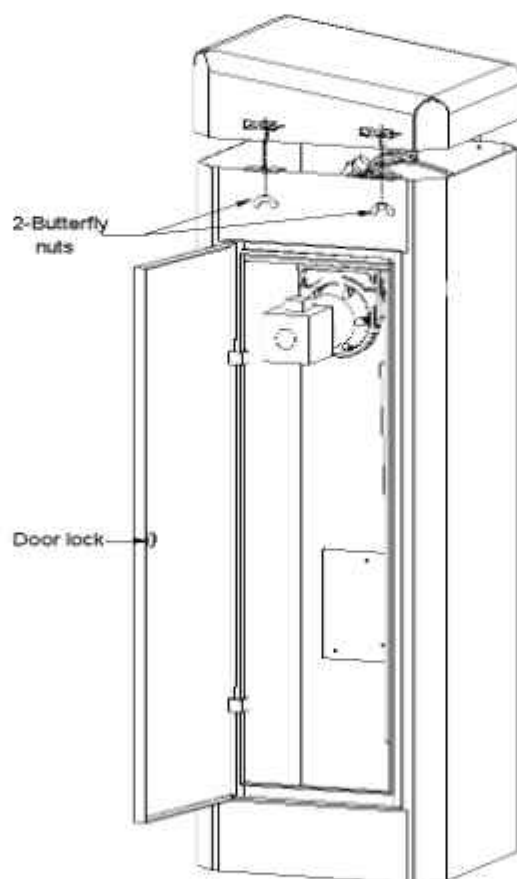
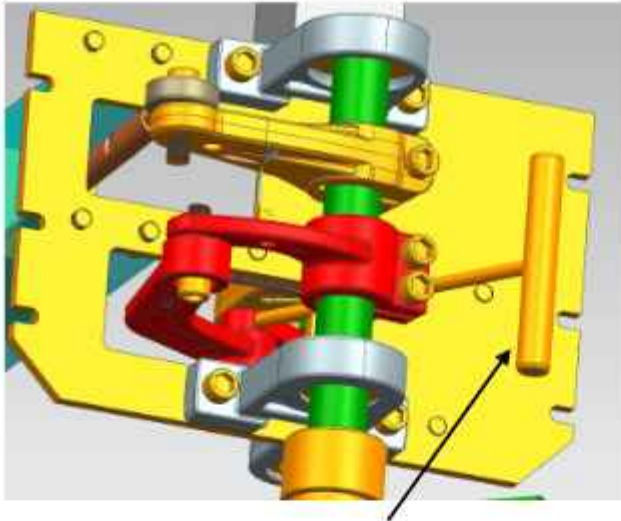
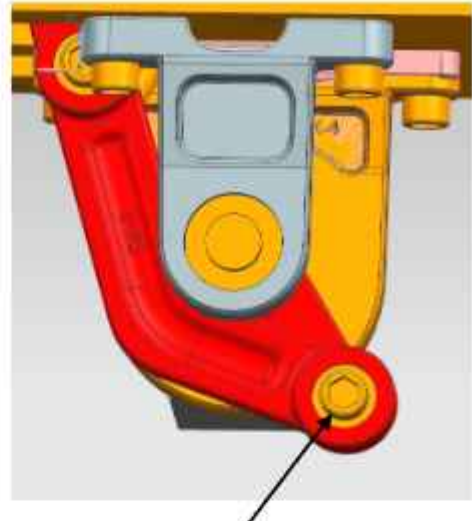

Figure 2-2



Push boom away from dead point position

Figure 2-3 (push to unlock)



pull boom away from dead point position

Figure 2-4 (pull to unlock)

2.2 Adjustment Spring Setting

According to the different boom length to assemble the compression spring, tighten or loosen the adjusted handle to make the boom maintain stable on 45°, this is the best spring strength. Until the boom keep stable on the position of 45° angle.

Exceptions:

When the barrier gates are set to automatically open when power failure, a greater spring force is required.

2.3 Testing Spring Setting

- 1) Open the door of barrier machine case with a key and remove the mounting plate.
- 2) Unplug the power cord.
- 3) Manually adjust the boom to the position of about 30 degree and release the hand. If the boom is stable in this position and not move, indicating that the spring adjustment is correct.

3 Power Connection

Connect the L, N to the air switch and PE connect to the ground screws (yellow-green line).

⚡ Important! Can be only use the randomly provided power connection cables to connect the main power supply (internal power has already connected in the factory).

Can't connect the AC power to the controller.

ⓘ Attention! After cut the power off, start the power supply prematurely will bring the damage to the equipment.

So: after cut off the power supply, wait for at least 10 seconds before start it again.

When using AC power, please put the SW1 toggle switch on the position of USE AC POWER. (Picture shown as below).

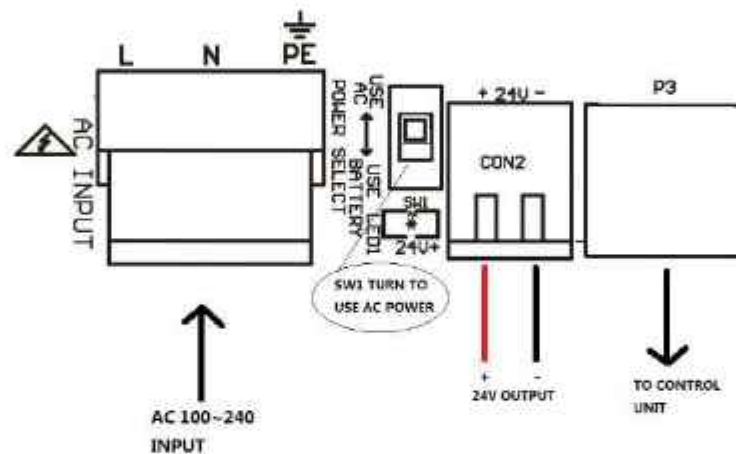

This barrier gate can be powered by 24V battery in the area without electric supply. Connection as follows:

⚡ IMPORTANT! Put the SW1 toggle switch on the power supply to use battery and confirm +, - polarity when connecting the battery. Do not reverse the battery.

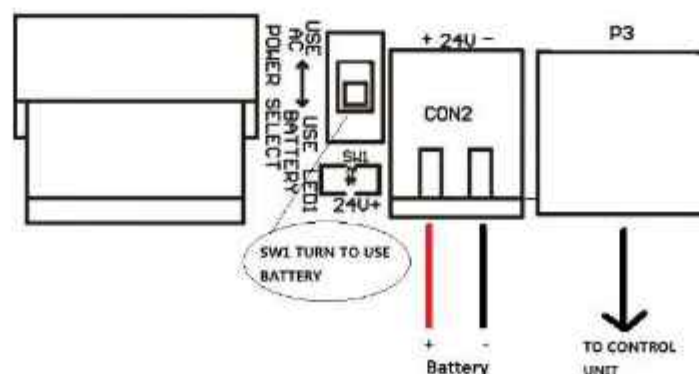

4 Control Board Introduce

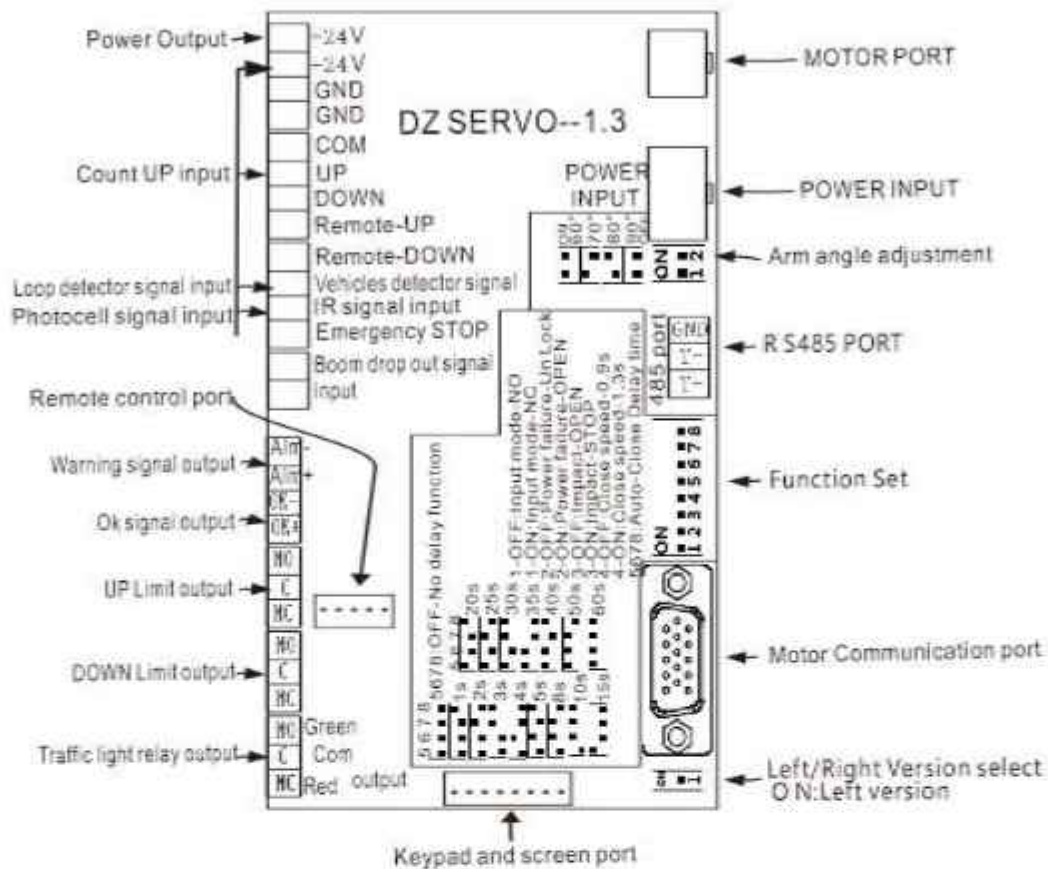

4.1 Function Instruction:

1. NO/NC mode selection, in the dip switch 1, ON for NC, OFF for NO.
2. Self-locking when power off or gate automatically open selection. In dip switch 2, ON is for automatic opening when power off.
3. Automatic reverse or stop selection when meets external obstacle. In dip switch 3, ON is for automatic stop and OFF is for automatic reversing.
4. Auto closing speed adjustment selection, in the dip 4, 0.9s and 1.3s for option. ON is for 0.3s.
5. Delay automatic closed selection. Dip switch 5,6,7,8 are for it and the delaying time is 1s,2s,3s,4s,5s,8s,10s,15s,20s,25s,30s,35s,40s,50s,60s for option.
6. The boom angle adjustment, suitable for some areas that the boom can't reach the vertical position caused by obstacle. Adjustable for 60°, 70°, 80° and 90°. And the dip switch is another independent one (1 2 switch).

7. Maintenance mode switch, convenient for possible repairing and adjusting.

4.2 Input Interface Introduction

1. RS485 interface, can connect with computer, check the barrier gate state and alarm information.
2. Parking lot open/close control signal and remote control open/close signal are separate. Arm opening have memory function, Number of pulse arm opening, and closed after number of cars (must be equipped with a vehicle detector).
3. Emergent stop input signal function.
4. Arm swing out signal input function.
5. Alarm information output function.
6. Barrier gate OK signal output function.
7. All input ports are optoelectronic isolation, the input voltage range is DC5 ~ 24V.
8. Vehicle detector signal input and infrared signal input, that is, use the output COM, NC of the loop detector (normally the No.4 and No.11, specially related with detector, the barrier gate not respond to closing command when the coil is not connected).The infrared detector uses the NPN type.

4.3 Output Interface Introduction

A. Line 1 barrier gate OK signal

It will be output after machine self-inspection, means the barrier gate working state is OK.

Type: NPN level switch, attention to the direction of + -, can't directly connect the + - power, it can be used only after inserted into the load, such as connect indicator or alarm or host computer acquisition port.

B. Line 1 barrier gate ALM alarm signal

When the alarm event occurs, this line output ALM alarm signal.

Type: NPN level switch, attention to the direction of + -, can't directly connect the + - of power, can be used only after inserted into the load, such as access indicator or alarm or host computer acquisition port.

C. Line 1 barrier gate vertical position signal, relay dry node signal (NC, C, NO).

D. Line 1 barrier gate horizontal position signal, relay dry node signal (NC, C, NO).

E. Line 1 10A R&G traffic light signal, relay dry junction signal (NC, C, NO), contacts can pass 10A current.

Alarm Information (the buzzer has different warning tone)

- a. motor line off alarm
- b. over-voltage alarm
- c. over-current alarm
- c. boom off alarm
- d. spring not installed, spring damaged alarm
- e. mechanical transmission structure loose alarm

4.4 Optional Functions

1. License plates recognition machine(LPR) and control panel

The boom will lift up automatically after LPR recognize and verify license plates (the function of control panel is similar with LPR) The wiring diagram is shown in the figure 4-1.

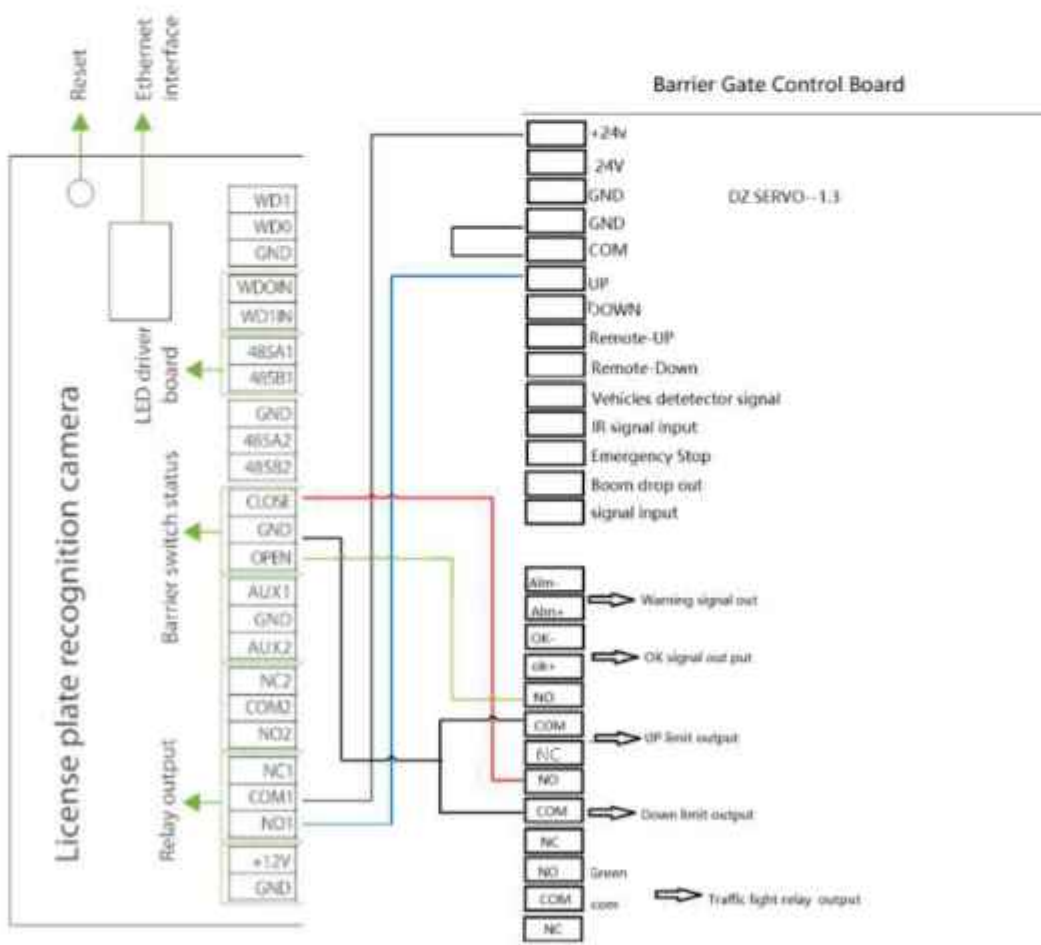

Figure 4-1

2. Loop Detector

Loop detector in the parking system consist of loop, loop detector and control board. The loop is installed under the ground. When loop detect a vehicle, the boom will not fall down, after the vehicle pass, the boom will automatically fall down. The wiring diagram is shown in the figure 4-2(if only use the Loop detector function, "the IR signal input" need be short connected with "+24V").

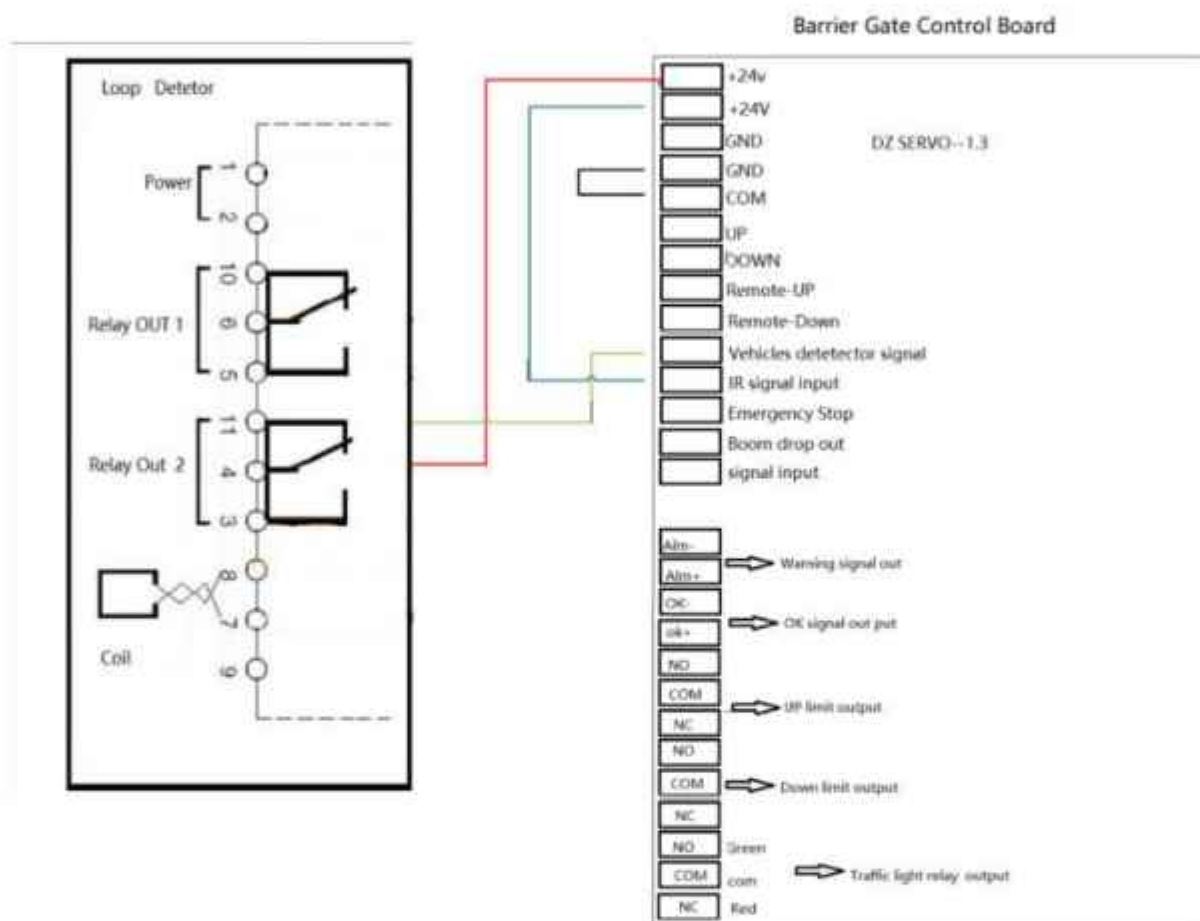
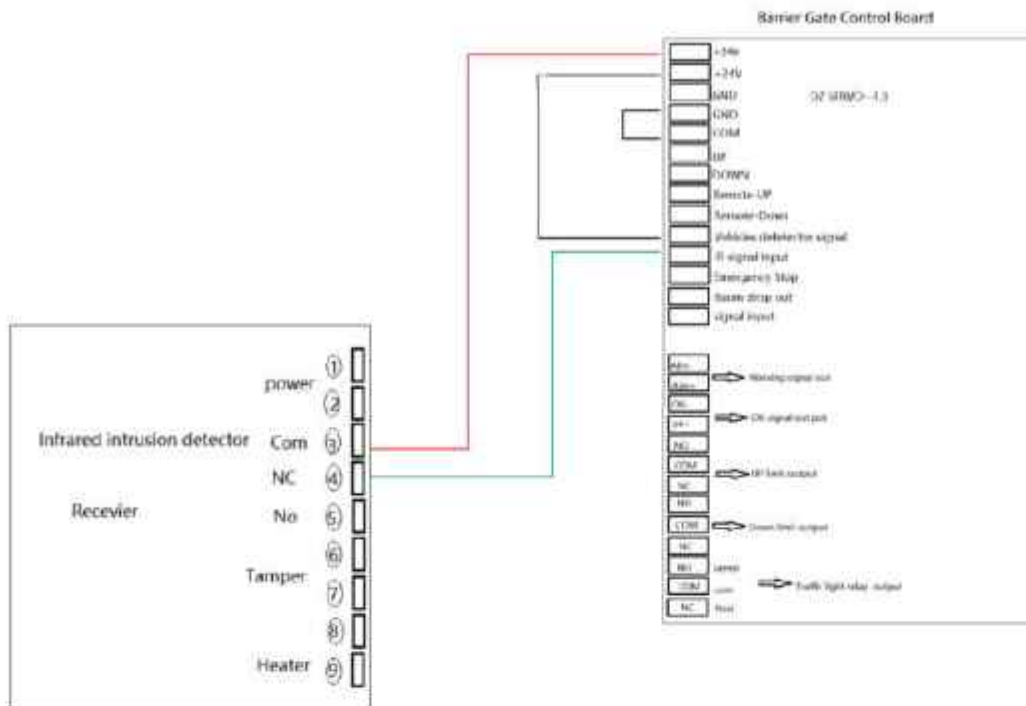

Figure 4-2

3. Infrared intrusion detector

If there have car or person between transmitter and receiver of Infrared intrusion detector, the boom will not fall down, after the vehicle or person pass, the boom will automatically fall down. The wiring diagram is shown in the figure 4-3.



Installation of The Infrared Photocell Beam Detector

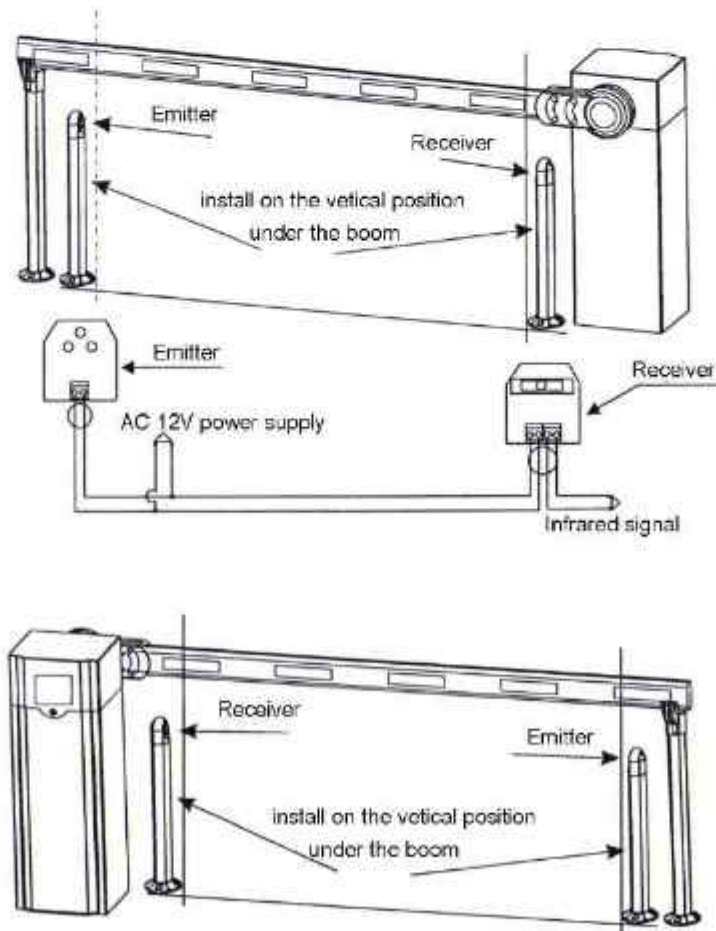

Figure 4-3

4. When the Loop detector and the IR be used at same time. The wiring diagram is shown in the figure 4-4.

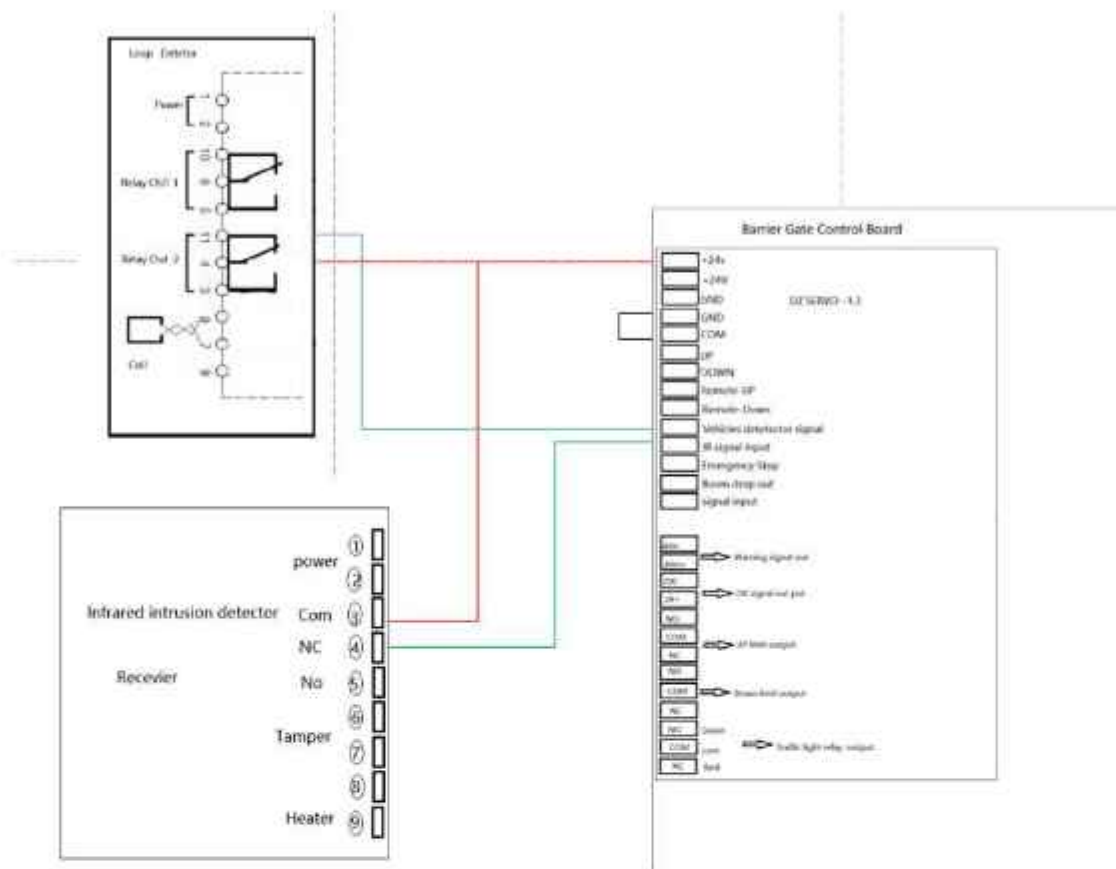

Figure 4-4

5. Wiring Diagram of the Push Button Station.

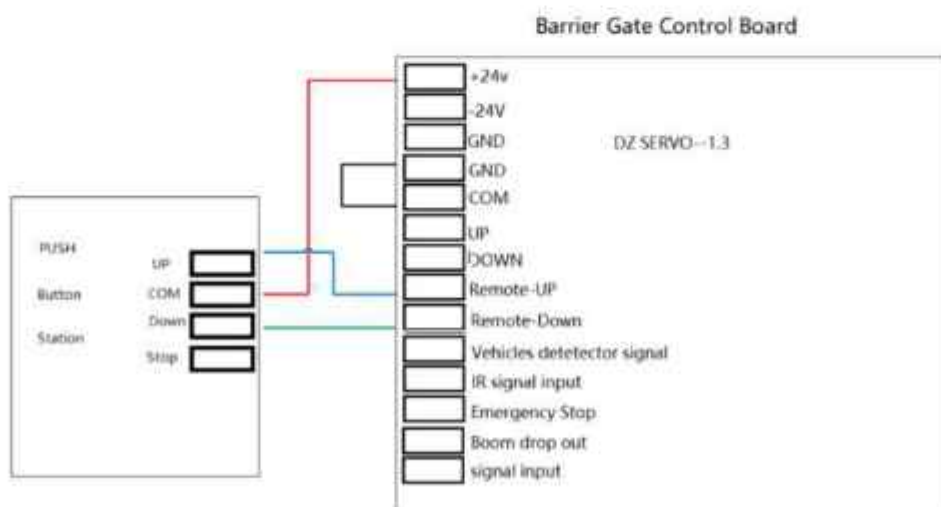

Figure 4-5

5 Appendix

5.1 Remote Control Learning Code Instruction

The remote control using special IC learning code remote controller, 418MHz wireless frequency, strong anti-interference, long remote control distance, that can up to 100meters in good weather, use easily and durable. The receiver of learning code remote control can store 16 different remote control codes, and support unlimited number of same code remote control. The external receiver learned the remote control within 5 seconds when power on, and re-power continue to learn when not finished. If repeat the learning, open the external receiver shell, there is a white button on circuit board, hold down 15 seconds to delete the remote control code, it can also press the white button to learn.

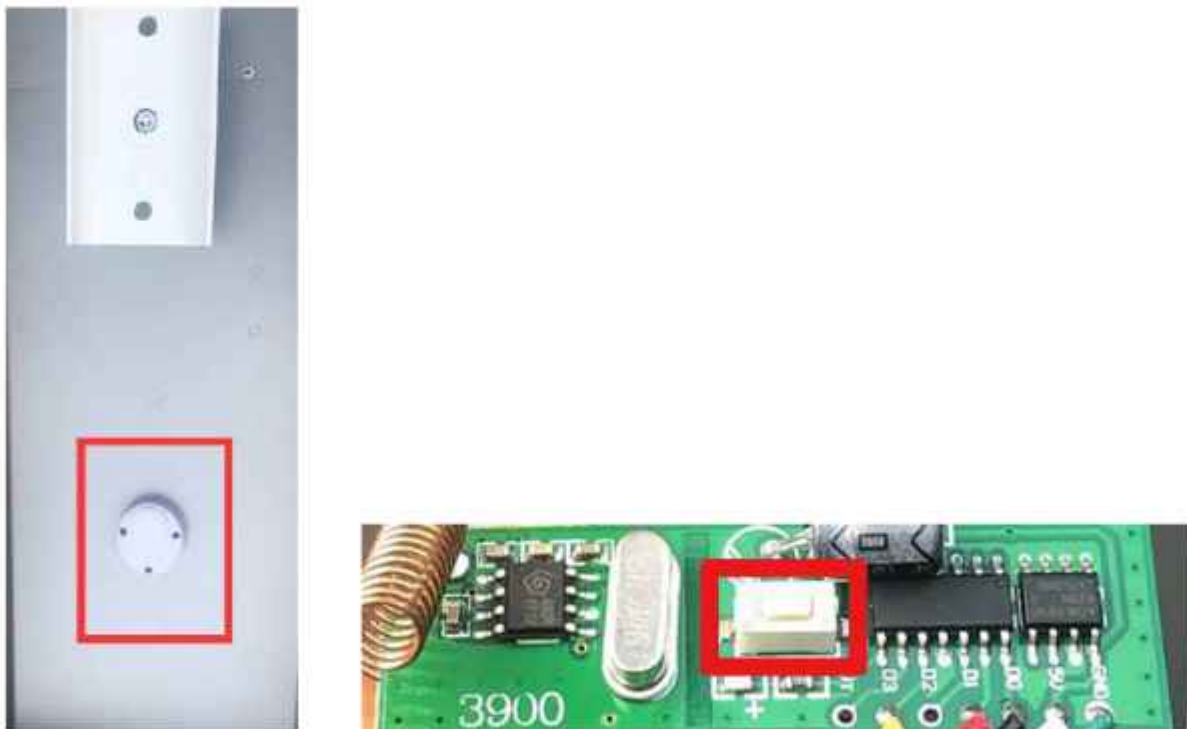

Figure 5-1

5.2 Up/Down Speed Parameter Adjustments Instruction

- **Parameter Name Explanation:**

D00spa name:- enter -program version

PA__00: parameter item

PA__AST: reset

****_Err:** false alarm

- **Key Description:**

Menu: menu key, switch in four parameters

L / R Arrow: Left and right movement keys, moves circularly, the corresponding characters flash

UP arrow: increase from 0 to 9, cycle key, add one for each pressing

ENTER: Enter key. Press ENTER at the currently displayed parameter to enter the specific parameter setting.

- **Parameter Explanation:**

1d0000, 2d0000, 3d0000, 4d0000: Indicates that the current parameter is 0000, which can correspondingly revise from the first to the fourth bit on the rightmost side.

Halfway return time parameters: PA__09 (range from 100 ~ 1500)

Up parameters: PA__10, PA__11 (range from 100 ~ 9999), PA__12 (range from 01 ~ 99)

Down parameters: PA__13, PA__14 (range from 100 ~ 9999), PA__15 (range from 01 ~ 99)

Down position parameters: PA__20 (range from 01 ~ 9999)

Up position parameter: PA__21 (range from 01 to 9999)

Resistance sensitivity: PA__23 (range from 10 to 99)

Boom level: PA__30 (range from 0 to 1)

ZK Building, Wuhe Road, Gangtou, Bantian, Buji Town,
Longgang District, Shenzhen China 518129
Tel: +86 755-89602345
Fax: +86 755-89602394
www.zkteco.com

